

**Metall-Folie,
das Präzisionsband zum:**

- Justieren von Apparaten
- Ausrichten von Maschinen
- Ausgleichen von Toleranzen
- Unterlegen von Vorrichtungen
- Anpassen von Aggregaten
- Einrichten von Werkzeugen
- Nachstellen von Schermessern

**Dickentoleranzen
Messing, Stahl nichtrostend**

Mat.-Dicke	Toleranz
0,01 – 0,03 mm	0,002 mm
0,04 – 0,05 mm	0,003 mm
0,06 – 0,18 mm	0,005 mm
0,20 – 0,30 mm	0,007 mm
0,40 – 0,50 mm	0,010 mm
Stahl: unlegiert	
Päzisionsabweichung DIN 1544	

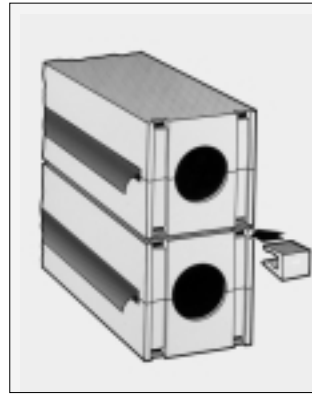

Dicke mm	Stahl unlegiert		Messing CuZn 37 MS 63		Stahl nichtrostend 18 Cr 9 Ni						10 Blatt 50x300mm	5 Blatt 150x500mm
	2500mm Breite 150mm	1500mm 150mm SK	2500mm 150mm	1500mm 150mm SK	5000mm 12,7mm	2500mm 25mm	2500mm 50mm	2500mm 150mm	1500mm 150mm SK	Box		
0,010	-	-	●	●	●	●	●	●	●	●	●	●
0,015	-	-	-	-	●	●	●	●	●	●	●	●
0,020	-	-	●	●	●	●	●	●	●	●	●	●
0,025	●	●	●	●	●	●	●	●	●	●	●	●
0,030	-	-	●	●	●	●	●	●	●	●	●	●
0,040	-	-	●	●	●	●	●	●	●	●	●	●
0,050	●	●	●	●	●	●	●	●	●	●	●	●
0,060	-	-	●	●	●	●	●	●	●	●	●	●
0,070	-	-	●	●	●	●	●	●	●	●	●	●
0,075	●	●	●	●	●	●	●	●	●	●	●	●
0,080	-	-	●	●	●	●	●	●	●	●	●	●
0,090	-	-	●	●	●	●	●	●	●	●	●	●
0,100	●	●	●	●	●	●	●	●	●	●	●	●
0,120	-	-	-	-	●	●	●	●	●	●	●	●
0,150	●	●	●	●	●	●	●	●	●	●	●	●
0,180	-	-	-	-	●	●	●	●	●	●	●	●
0,200	●	●	●	●	●	●	●	●	●	●	●	●
0,220	-	-	-	-	●	●	●	●	●	●	●	●
0,250	●	●	●	●	●	●	●	●	●	●	●	●
0,300	●	●	●	●	●	●	●	●	●	●	●	●
0,350	-	-	-	-	●	●	●	●	●	●	●	●
0,400	●	●	●	●	●	●	●	●	●	●	●	●
0,450	-	-	-	-	●	●	●	●	●	●	●	●
0,500	●	●	●	●	●	●	●	●	●	●	●	●
Sortiment 25/100					Inhalt: Messing je 150 x 1200 mm 0,025 mm, 0,050 mm, 0,075mm, 0,100 mm						●	

- = nicht lieferbar
● = lieferbar
SK = selbstklebend

